



EPS-MICRO PLUS

EPS-MICRO is strictly a driver assistance device, and should not be relied upon as a security device or a substitute for safe driving practices.
Use common sense when reversing, and always follow recommended safe driving guidelines from your local, State or County Department of Motor Vehicles regarding engagement of reverse gear.

MOUNTING INSTRUCTIONS

1. WORKING PRINCIPLE

The **EPS-MICRO PLUS** is a parking sensor device that employs electromagnetic waves of low energy and is able to detect the approach of an obstacle of any kind.
The activation of the device happens, without additional manoeuvres, at the engaging of the back-gear and is confirmed by a signal of "OK".

Once activated, the **EPS-MICRO PLUS** generates around the bumper, on which is installed, a zone of protection (Fig. 2).

When any obstacle, entering the zone of protection, approaches to the bumper, a series of acoustic signals is given.

A) At the insertion of the back gear a check of the entire system is done;

If the control is positive a signal of **OK** is emitted constituted by three notes in rapid succession for confirm the regular operation capability of the system.

B) During the approach to an obstacle the electronic unit activates the acoustic signalling beginning from a distance between bumper and obstacle (measured in the central zone of the bumper) of around 60-70 cm with 3 types of signals:

1) **An increase in sequence** of "BEEP" informs the driver that an obstacle is approaching (alert signal)

2) **A continuous sound** when the obstacle arrives in proximity of the bumper at a variable distance between 15 to 30 cm according to the type of obstacle. These values correspond to the central zone of the bumper while on the side edges the distance is inferior.

3) **A continuous sound at a different lower frequency** when an obstacle is very near to the bumper (10-15 cm) in order to give an impressive alarm of possible contact.

Note: the antenna sensor is not proper to be applied on metallic bumper or plastic bumper with metallic reinforcement to contact directly of the inside wall of the same.

2. TECHNICAL CHARACTERISTICS

- Operation voltage from 10.5 to 18 V
- Average current absorbed: 50 ma
- Temperature of operation from - 20 to +70 °C
- Average distance of beginning revelation: 0.6 m

3. MOUNTING NOTES

The installation of the antenna sensor, constituted by an aluminium adhesive ribbon must, be performed to the inside of the bumper. It is **of high importance** that the zone of application on the inside surface of the bumper corresponds to the **higher part** as regards the ground but also the **most distant** from the car body.

The electronic unit must be mounted inside the trunk and the antenna sensor on the inside surface of the bumper following the procedure of the points 4.1 and 4.2.

Note: The system is able to work correctly when the antenna sensor, once applied on the bumper, is outdistanced, on all

his length, of at least 3 cm from the metallic structure of the vehicle. If the antenna approaches (at a distance inferior of 3 cm) to the structure only for short distance, the correct operation is equally guaranteed.

4. MOUNTING OF THE SENSOR

4.1 Apply the electronic unit to the inside the trunk

a) Open the trunk.

b) Identify on the car body the zone close to the extremity of the bumper and, on the side where it is present the back-gear lamp, a possible hole of passage toward the interns of the trunk in order to carry out the connection cable from the electronic unit to the antenna sensor

In the case in which it is not possible to find an adequate passage already existing practise a small hole with a drill in correspondance of the back-lamps right or left group where it is usually present also the backing light.

c) Clean carefully with alcohol or solvent the surface where will be positioned the electronic unit.

d) Apply the electronic unit using e piece of sticking material practising a strong pressure in order to have a strong attachment.

4.2 Application of the antenna sensor to the inside of the bumper

a) At one extremity of the bumper individuate the position where to place the beginning of the antenna with connector so that it will be situated, once remounted the bumper, on the part where it will be provided the passage to the car inside.

Apply this extremity with a piece of sticking material used as reinforcement and begin the application of the ribbon of adhesive aluminium (antenna sensor) practising a strong pressure in order to have a strong attachment on the inside surface of the bumper. Cut the part of the ribbon not used and fix strongly the extremity again with the special sticking material.

b) In order to assure a better installation it is advisable to cover all the zone of application of the ribbon with plastic protection primer.

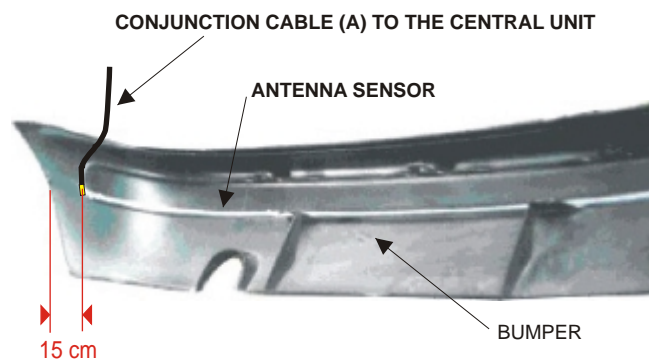

Fig.1 - Sight of antenna assemblage inside bumper

5. ELECTRIC CONNECTIONS

5.1 Electric Connection of the electronic unit.

a) Connect the electronic unit to the antenna connection cable and make it go out of the car body through the passage already previously individuated or practised.

b) Insert the connector of the cables of power and buzzer in the unit.

c) Replace provisionally the bumper on the car.

d) Make the connection to the antenna sensor already stucked on the bumper using the cable **A** and crimping both the wires on the fast-on provided.

5.2 Electric Connection of the cables

a) Connect the red wire coming from the white connector to the positive cable that is powering the back gear lamp.

b) Connect the black wire to the earth cable of the rear lamp (negative).

c) Connect the speaker (acoustic transducer) using the respective connectors.

6. MOUNTING OF THE ACOUSTIC TRANSDUCER

Fix the speaker in an appropriate place in order to assure a good sonorous perception at the driver.

7. FINAL TEST PROCEDURE

Switch on the car key and insert the back gear.

a) In a fraction of second the electronic unit performs a complete control of the system and, if everything is correct, the speaker makes a sound of "OK" (three notes in rapid succession). Once obtained this signal the system becomes operational. If the acoustic speaker doesn't give any signal check all the connections
ATTENTION: if at the insertion of the back gear the acoustic speaker gives an alarm signal (two notes for three times) it means that the **antenna connection is missing** or not correct.

b) Departing from around 1 meter of distance from the center of the bumper walk near slowly for simulate a backing manoeuvre of the car.

At a distance of around 60/ 70 cm it will be perceived the first acoustic signals (Biip...Biip...) whose frequency of repetition will increase at the decrease of the distance to become a first continuous sound at around 20-30 centimeters.

A second continuous sound (third signal indicating risk of contact) of lower frequency will come at few centimeters from the bumper.

c) If the system shows to work regularly it is possible to fix definitely the bumper.

Note: The **EPS-MICRO PLUS** is able to detect the obstacles that approach near the bumper with a signaling of so much quick and evident alarm as more the obstacle is near.

Starting to give the signaling only when the vehicle is being approached to the obstacle, a fixed object in front of the bumper, for instance the hauls hook or the sides walls of a car box, is not signaled and it is not bothered the normal operation of the device.

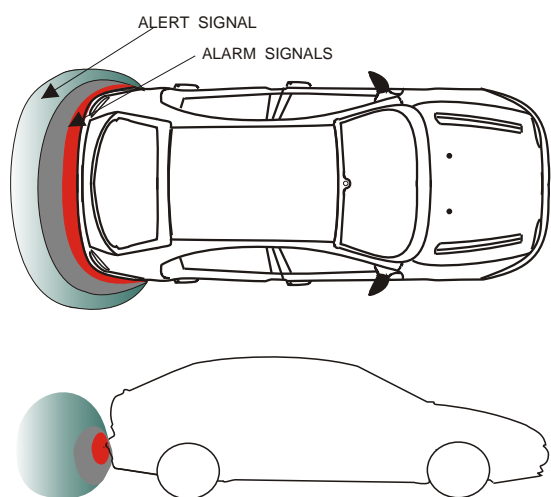

Fig. 2 Sight of protection area

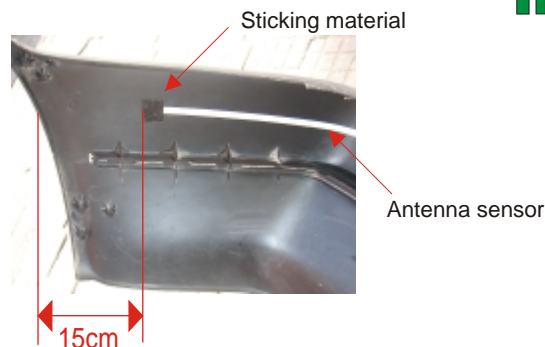

Fig. 3 Sight of the end part of antenna sensor

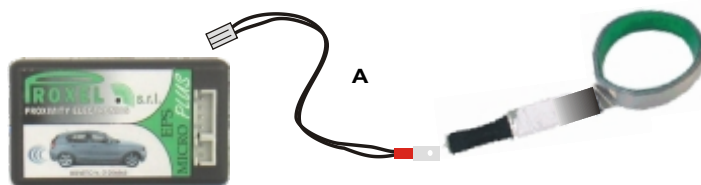

Fig.4 Sight of the central unit , antenna connecting cable and antenna

WARNINGS

- 1) As soon as the system is activated an acknowledgement of the surrounding of the bumper (antenna sensor) is made.
- 2) Consequently **it is very important**, during testing operation, not to switch on the system while you are very close to the central unit and antenna sensor in order not to have false information on the working capability of the system. During the test be careful that **AFTER THE FIRST APPROACH** to the bumper any **FURTHER APPROACH** without resetting the unit (switch off) can give false interpretations of the capability of the system because of a peculiar behavior of the software properly made for reducing false signals during raining conditions.
- 3) In presence of rain or high moisture weather, the system reduces his sensibility automatically in order to eliminate a part of false alarms that could be given by movement of water on the bumper. In this situation the system could give only the last low frequency signal (risk of contact)
- 4) Due to the operating principle of the EPS sensor and depending on mounting position of the antenna sensor the unit can give sound warning alert signals in error as the vehicle reverses. This is due to ground pick up and is normal.

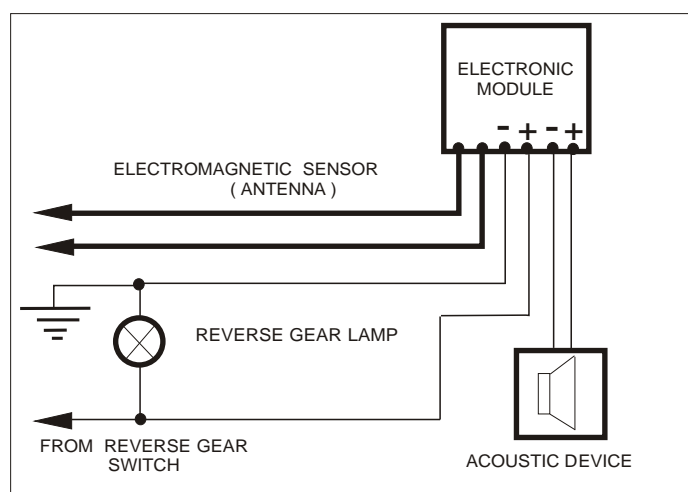

Fig. 5 - Electric schematic of connections