

INSTALLATION INSTRUCTIONS & USER MANUAL

Rear parking sensor

mod. EPS-DUAL4.0 with WIRELESS DISPLAY

1 STARTING PROCEDURE

a) The installation of the antenna sensor, constituted by an aluminium adhesive ribbon, must be applied to the inner surface of the bumper. It is **of some importance** that the zone of application corresponds to the **higher part** as regards the ground but also the **most distant** from the car body.

b) Identify on the car body the zone close to the extremity of the bumper and, on the side where it is present the back-gear lamp, a possible hole of passage toward the intern of the trunk in order to carry on the data cable to the antenna sensor.

2 POSITIONING OF ANTENNA SENSOR

A- Thoroughly clean with alcohol or nitre solvent the inner surface of the bumper of the zone previously identified on which will be applied the antenna sensor.

B- Fix through its adhesive the black connection module of the data cable on the inner surface of the bumper, starting from approximately 10-15 cm away from the end of the bumper

C- Connect the black module of the Data cable coming from the ECU to the antenna sensor. and fix it on the bumper by a strong pressure. When arrived at the opposite side of the bumper cut off the antenna in excess and fix the extremity using a piece of sticking material

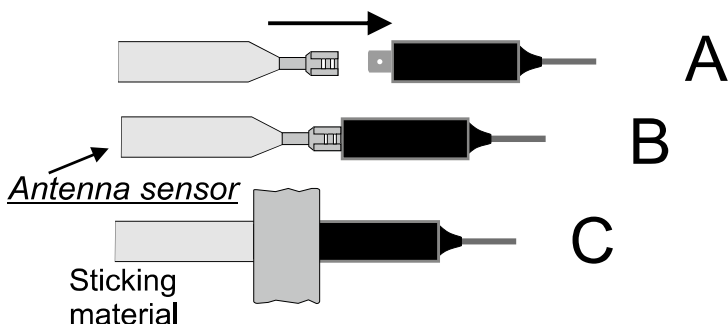

3 DISPLAY ELECTRICAL CONNECTION

Fix the Display in the appropriate position to your liking, using the double-sided tape, in order to also ensure good sound perception by the driver.

b) Connect the black wire of the Display power cable to a good earth point.

c) Connect the red wire of the 12 Volt power cable under key so that the Display is activated when the instrument panel is turned on. **Fig.2**

NOTE: Some vehicles are equipped with a metal crash protection bar insert facing the inside surface of the bumper. When this metal surface is too close to the inner surface of the bumper where you have placed the antenna sensor, the detection distance can be reduced.

To adjust the signalling distance it is sufficient to change the slide-switch positions (see **Fig 3**) Take care that the sensitivity No 1 is the lowest and the number 4 is the largest.

4 TESTING PROCEDURE

a) Switch on the instrument panel and engage reverse gear.

In a fraction of a second the control unit performs a check of the functionality of the system and, if the system has been mounted correctly, three red dots light up on the display. Once this signal is obtained, the system becomes operational.

VERY IMPORTANT is not to carry out experimental tests (on bench) before having completely assembled the kit with the antenna applied to the bumper because the system does not work properly without the presence of the metal mass of the vehicle.

Possible problems and their solutions

1- If the buzzer emits **8 consecutive quick beeps** and **AL** on the display, check the data cable and its connection to the control unit and that there is no short circuit between the antenna sensor and the metal body.

2- If the buzzer emits **3 consecutive beeps** and **ST** on the display, check the connection of the Data cable with the antenna sensor.

b) Starting from about 1 meter away from the center of the bumper, slowly approach both hands to simulate a parking maneuver. At a distance of about 60/70 cm will be heard the first acoustic signals whose repetition rate will increase at the decreasing distance to become a fast intermittent sound and then a continuous higher frequency sound at about 10-15 cm from the bumper.

c) If the system shows to work regularly it is possible to fix definitely the bumper.

Note: EPS-DUAL 4.0 starts to give the signalling **only** when the vehicle is being approached to the obstacle; a fixed object in front of the bumper, for instance the **license plate**, the hauls hook or a bull bar or the sides walls of a car box, is not signalled and it is not bothered the normal operation of the device.

USER MANUAL

The activation of the device is obtained by the insertion of the back gear and confirmed by a signal of "OK". Once activated, the EPS-DUAL 4.0 generates around the bumper, on which is installed, a protection zone (Fig. 1).

When any obstacle present in the protection zone tends to approach the bumper you will hear a series of beeps.

WORKING EXAMPLE

A) Upon activation, the functionality of the system and the radio transmission of the signals from the control unit to the Display are carried out in a very short time.

If the Display is connected (via radio) to the control unit, **three red luminous points** appear immediately on the display. If, when this reverse gear is engaged, no sound is emitted and the green, yellow and red LEDs of the Display do not light up when the obstacle approaches, check the connection of the antenna sensor and the control unit to the Data Cable.

If the three luminous points do not appear when reversing, check all the connections both on the Display and on the control unit.

B) When approaching an obstacle the system activates the acoustic and display signal at a distance between the bumper and obstacle (measured in the central area of the bumper) of about 70 / 80 cm with 3 types of sounds:

1) Lighting of the first two green segments on the display to inform the driver that an obstacle is approaching.

2) Intermittent sound with an increasing repetition frequency simultaneously with the 3 yellow LEDs and the word **AL** in the center of the Display (ALARM) when the obstacle arrives near the bumper at a distance ranging from 15 to 30 cm.

3) Lighting of the first red led, followed by the second with a continuous sound together with the writing **St** (STOP) when an obstacle is very close to the bumper (10-15 cm).

Note:- The detection is depending on the size of the obstacle and while the max corresponds to the central zone in the lateral edges the distances of detection are less (see Fig. 1)
- The alert occurs only when the vehicle is approaching an obstacle, a fixed object in front of the bumper is only detected after the first movement of approach.

WARNING

In presence of rain or high moisture weather, the system reduces his sensibility automatically in order to eliminate a part of false alarms that could be given by movement of water on the bumper near the antenna.

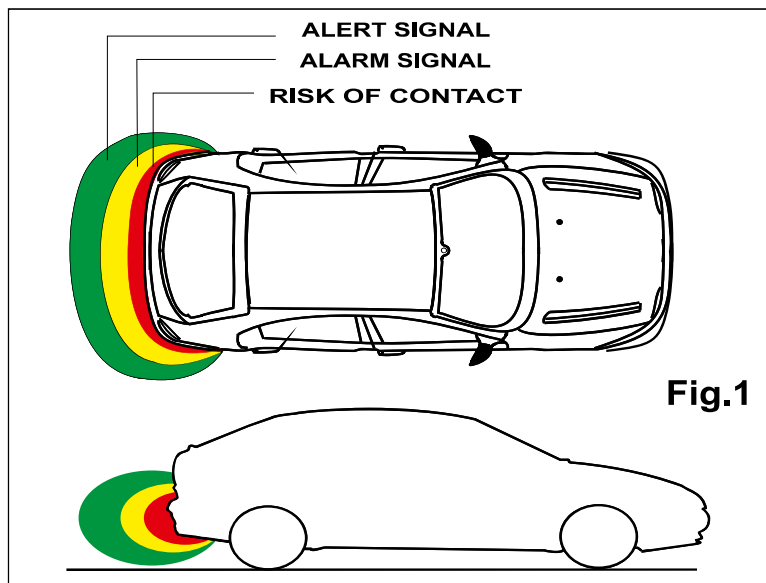

Fig.1

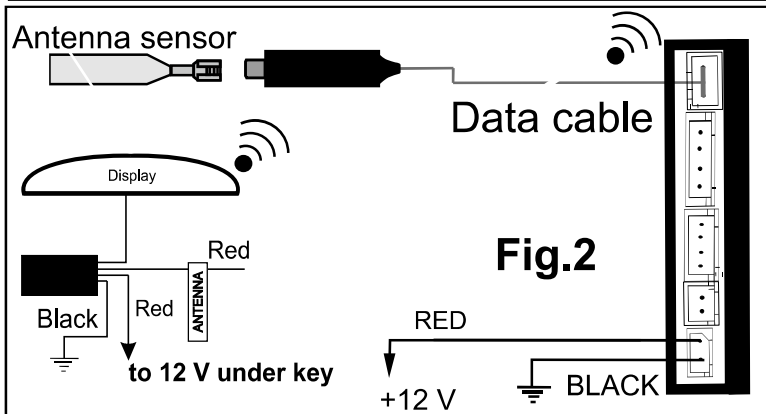

Fig.2

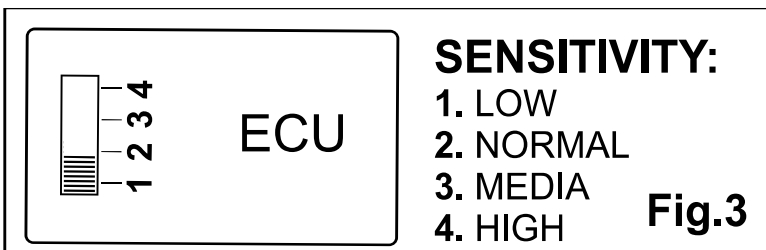
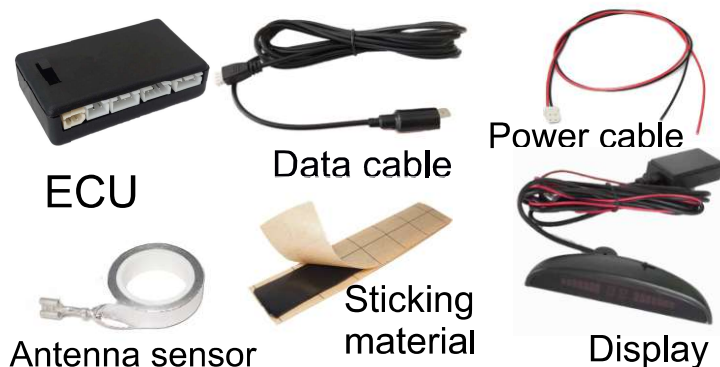

Fig.3

ELECTRICAL CHARACTERISTICS

- Operating Voltage from 9,5 to 18V
- Average current absorption 20 mA



PROXEL S.r.l. - Via Val Della Torre 39 - 10149 - TORINO (ITALY)

Tel. +39 011 296022 - Fax +39 011 2218053

Technical Assistance: eps@proxel.com