

1 STARTING PROCEDURE

a) The antenna sensor, constituted by a very strong aluminium adhesive tape, must be applied to the inner surface of the bumper and in the **higher part** as regards the ground.

b) Locate a passage where, from the driver's place behind the dashboard, it is possible to route the DATA CABLE into the engine compartment up to the extremity of the bumper.

We suggest to use the interspace that is separating the engine compartment from the lateral outside surface of the car body.

The right place where to find it is close the driver door hinge.

2 MOUNTING THE ANTENNA SENSOR

A- Thoroughly clean with alcohol or nitro solvent the inner surface of the bumper of the zone previously identified on which will be applied the antenna sensor.

B- Place the black fast-on connector of the data cable to the internal surface of the bumper using its double-sided tape, starting from about 10-15 cm from the bumper end and connect the antenna sensor.

C- Coat the connection with a piece of adhesive putty.

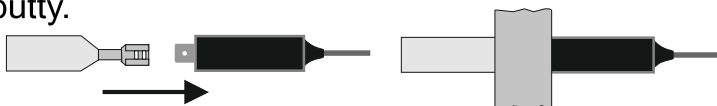

After connecting the antenna sensor, you can start placing the tape on the bumper by applying strong pressure in order to make it adhere well to its internal surface. After application, the excess part of the tape can be cut off.

NOTE: Even if the **metal license plate** covers the antenna sensor, it does not disturb its obstacle **detection capacity** in that area.

3 ELECTRICAL CONNECTIONS

The control unit can be placed under the dashboard and the activation button together with the buzzer in a suitable place.

Connect the red wire of the power supply cable to the 12V positive under key and the black cable to a good ground point. Place the activation button in a suitable place on the dashboard and connect the **red wire** to the plus and the **black wire** to the minus. The other two wires to the **other two contacts** indifferently (Fig.2).

NOTE: Some vehicles are equipped with a metal crash protection bar insert facing the inside of the bumper. When this metal surface is too close to the inner surface of the bumper where you have placed the antenna sensor, the distance signal can be reduced.

To adjust the signaling distance is sufficient to change the slide-switch positions (**FIG3**).

4 FINAL TESTING PROCEDURE

a) Turn on the key, press the push-button. In a fraction of second the control unit performs a check of the functionality of the system and, if everything has been done correctly, the buzzer emits an acoustic sound of "OK" (one note). Once you have this signal the system becomes operational **but automatically deactivates after 2 minutes with a special sound.**

VERY IMPORTANT is not to carry out experimental tests (on bench) before having completely assembled the kit with the antenna applied to the bumper because the system does not work properly without the presence of the metal mass of the vehicle.

Possible problems and their solutions

1. If the acoustic transducer does not emit any signal check all the connections.

2. If the transducer emits an audible warning signal consisting of 2 notes (one high and one low) repeated 3 times) check the connections of DATA cable to the antenna sensor.

3. If the buzzer produces 8 consecutive fast beeps check the DATA cable connection on the central unit.

b) Starting from about 1 meter away from a wall, approach **very slowly** to simulate a parking maneuver. At a distance of about 50/60 cm the first acoustic signals will be heard, the repetition frequency of which will increase as the distance decreases to first become a fast intermittent sound and then continuous at about 10-15 centimeters from the bumper.

NOTES:

1. EPS-FRONT 4.0 is able to detect obstacles that tend to approach the bumper with an alarm signal all the more prompt and evident the closer the obstacle is located. By activating the warning **only when the vehicle is approaching** the obstacle, a fixed object in front of the bumper, for example the "bull bar", the **license plate** or the side walls of a garage, are not signaled and the normal operation of the device is not disturbed.

2. The front obstacle detection system must **obligatorily** be controlled via the button only when necessary, as it cannot always remain active during travel as the advancement of the car **would continually produce false signals.**

USER MANUAL

The activation of the device is obtained by pressing the activation button and confirmed by a signal of "OK". Once activated, the EPS-FRONT 4.0 generates around the bumper, on which is installed, a protection zone (Fig. 1).

When any obstacle present in the protection zone tends to approach the bumper you will hear a series of beeps.

If you want to deactivate the system, simply press the button a second time and a different acoustic signal warns you of deactivation, otherwise it deactivates automatically after **2 minutes**.

When approaching an obstacle the system activates the acoustic signal at a distance between the bumper and obstacle (measured in the central area of the bumper) of about 50/70 cm with 2 types of sounds:

1) an increase in sequence of "BIP" (alert) informs the driver that an obstacle is approaching.

2) continuous sound at a more acute frequency (risk of contact) when an obstacle is very close to the bumper (10-15 cm).

Note:

- The distances will vary depending on the size of the obstacle and corresponds to the central zone of the bumper; on the lateral edges the distances is less (Fig. 5)

- The alert occurs only when the vehicle is **approaching an obstacle**, a fixed object in front of the bumper is only detected after the first movement of approaching.

- The **ON / OFF** switch on the buzzer is blocked because it cannot be used in this version.

WARNING

In presence of rain or high moisture weather, the system reduces his sensibility automatically in order to eliminate a part of false alarms that could be given by movement of water on the bumper.

In this situation, the alarm zone could be eliminated and only the risk of contact signal is maintained (Fig. 1).

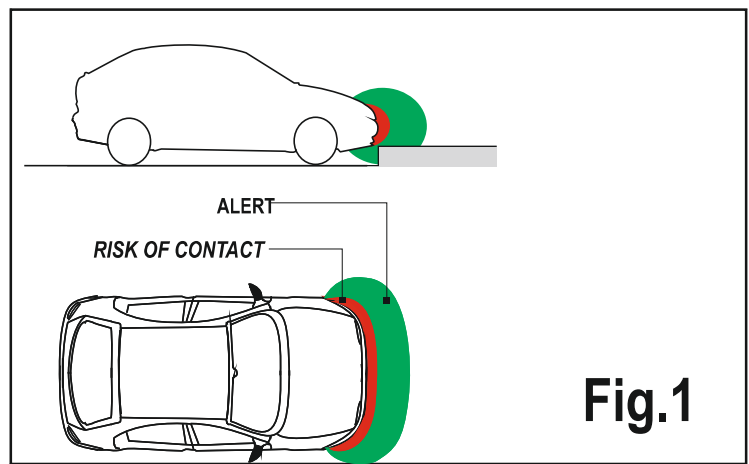

Fig.1

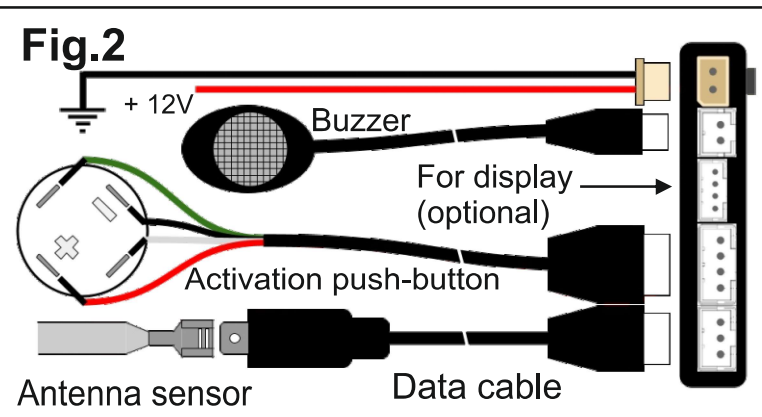
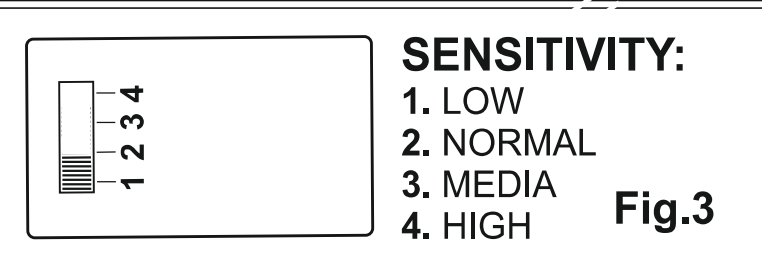

Fig.2



SENSITIVITY:

1. LOW
2. NORMAL
3. MEDIA
4. HIGH

Fig.3

TECHNICAL CHARACTERISTICS

Operating range: from 9,5 to 18 V
Max current absorption: 70 mA

- Operating temperature from -20°C to +90 °C
- Max. Distance to begin detection 40-50 cm

